

<https://doi.org/10.32056/KOMAG2024.3.5>

Peaking water power plant powered by mine water

Received: 12.08.2024

Accepted: 10.09.2024

Published online: 02.10.2024

Author's affiliations and addresses:

¹ *retiree*

² Silesian University in Gliwice
Akademicka 2
44-100 Gliwice, Poland

³ KOMAG Institute of Mining
Technology
Pszczynska 37
44-101 Gliwice, Poland

* Correspondence:

e-mail: kniespialowski@komag.eu

Stanisław MIKUŁA¹, Jarosław MIKUŁA²,
Krzysztof NIEŚPIAŁOWSKI^{3*}, Marek KALITA³,
Krzysztof TURCZYŃSKI³

Abstract:

A water power plant in a mine is an innovative solution that can use rainwater, underground and industrial water collected in mines to produce electricity. The process involves pumping water to a higher level and then draining it down, which drives turbines that generate electricity. Another solution may be to direct the water from higher levels to lower levels to the turbine blades. This approach allows for the effective use of existing mine infrastructure, contributing to sustainable development and reducing greenhouse gas emissions. Additionally, it helps manage mine water, offering a stable source of energy for local communities and industry. Examples of operating water power plants in mines around the world confirm their effectiveness and economic benefits, indicating the potential of this solution in green energy.

Legal requirements related to using the energy of a water stream in a technical device (generator) in a mining plant, an overview of existing solutions and an original concept of a water power plant with a tubular vertical shaft are presented.

Keywords: water power plant, underground mine, hydro-generator, water power plant with a tubular vertical shaft



1. Introduction

As a result of the energy crisis in 1973, most developed countries took actions whose main goal - among other things - was to create new sources of electricity not based on fuels (especially liquid fuels), but using the renewable energy. Among these new sought sources, hydropower has come to the fore. Therefore, small power plants and water power plants that had been shut down in previous years aroused great interest. This was due to very low oil and gas prices, which led to a lack of competition with high-capacity power plants using fossil fuels. Interest in the possibility of using existing water dam structures for energy purposes for various water and economic purposes has resulted in the intensive development of small hydroelectric power plants, which include hydroelectric power plants with a capacity of approximately 5 MW, and in some countries even up to 10 MW [1].

In addition to using water in the above-mentioned structures, research work has begun on the development of using the subsurface water as a source of energy. This mainly concerns mine water, the energy associated with its flow can be used to produce electricity [2]. Systems producing electricity from mine water have been created, but for many reasons (including economic ones) they have not been widely implemented so far. It was only at the end of 2023 that a power generator was launched in the liquidated Boże Dary mine in Katowice [3]. The system uses the energy of water dropped from a level of 183 m to a level of 416 m. This water drives a hydro-generator located at the 416 m level. The produced electricity is directed to the network used by the mine's pumping station.

Another solution may be a power plant generating electricity during peak or emergency demand, closely linked to the operation of the main drainage installation for underground workings of deep mines. Very large amount of seam and technological water is pumped out of mine underground. On the surface, this water has high potential energy relative to the underground reservoirs from which they are pumped off. During peak hours or in emergency situations, this enables using this energy for production of electricity using a water power plant. The key issue of the solution is to supply the power plant turbine with water from the main discharge pipeline, i.e. contaminated water, as well as to use a special solution for the vertical tubular shaft bearing and effective lubrication and cooling of the main components of the power plant. This will enable obtaining higher specific power, high durability and quiet operation of the power plant. The vertical layout of the power plant covers much less space in the limited underground infrastructure of mines.

The power plant can be activated in a very short time, which is particularly important in emergency and crisis situations. It also has a high level of resistance to natural disasters, terrorist attacks and warfare.

2. Legal regulations and associated documents

Use of the energy of a water stream in a technical device (generator) in a mining plant requires compliance with the following legal acts:

- Act of June 9, 2011 - Mining and Geological Law, which specifies the principles and conditions for undertaking, performing and terminating activities in the field of: geological works, extraction of minerals from deposits, underground non-tank storage of substances, underground storage of waste [4].
- Regulation of the Minister of Energy of November 23, 2016 on detailed requirements for the operation of underground mining plants [5].

Art. 2, Item 1 of the Act [4] says, among other things, that the provisions of the above-mentioned the Act, with the exception of Chapter III of the Act (dedicated to concessions), shall apply accordingly to the following:

1. construction, expansion and maintenance of drainage systems for closed mining plants;
2. work in the workings of liquidated underground mining plants, listed in the regulations issued on the basis of section 2, for purposes other than those specified in the Act, in particular tourism, medical and recreational purposes;



3. underground work for scientific, testing, and training activities for the purposes of geology and mining;
4. tunnel drilling using mining techniques;
5. liquidation of facilities, equipment and installations referred to in Items 1- 4.

Additionally, the provisions of the Act of July 20, 2017 - Water Law [6] should be taken into account, where in Section I, Chapter I, Art. 7, Item 1, point 3 there is a provision stating that the Act do not apply to the introduction of water into the rock mass from the drainage of mining plants and the use of water referred to in Item 2. point 2, in turn, states that the provisions of the Act do not apply to the use of water collected using devices and technical installations that are not water devices. According to the definition available on the website of the State Water Holding Wody Polskie [7], it can be read that water facilities construction of which requires a water permit include the following:

- damming, flood protection and regulation devices or structures, as well as canals and ditches,
- artificial reservoirs located on flowing waters and facilities related to these reservoirs,
- ponds - in particular fish ponds and ponds intended for sewage treatment or recreation (excluding ponds that are not filled as water services, but only with rainwater or meltwater, or groundwater of an area not exceeding 5,000 m² and a depth not exceeding 3 m from the natural land surface, with the scope of impact not exceeding the boundaries of the area the plant owns, or the area within the area of impact, if the plant has the prior written consent of the owners of the land affected by the impact to construct a pond - these require a water law notification,
- facilities for capturing surface water and groundwater,
- hydropower facilities,
- outlets of sewage devices used to introduce sewage into water, land or water facilities and outlets used to introduce water into water, land or water facilities,
- permanent devices used for catching fish or obtaining other aquatic organisms,
- devices for breeding fish or other aquatic organisms in surface waters,
- retaining walls, boulevards, quays, piers, piers and marinas,
- permanent devices used for inter-coastal transport.

Please remember that other devices or structures used to shape water resources or use these resources may also be classified as water facilities.

3. Samples of the existing solutions

There are well-known examples of energy recovery from falling water, in particular the so-called Small Hydroelectric Power Plants (SHPP), based on hydro-generator sets, consisting of an electric generator driven by a turbine, which in turn is powered by a water stream [8].

According to the report [9], at the end of June 2021, 775 SHPPs were operating in Poland. The total capacity of such installations was 296 MW.

The only known concept of a solution similar to the one described in this article is the plan to use the workings of the Prosper-Haniel mine in Bottrop as a pumped-storage power plant. Information about this comes from publications 2017-2018 [10, 11, 12, 13, 14]. However, information published in the cited references is a description of a concept that has not been finalized yet. Nevertheless, post-mining areas are gradually revitalized [15].

Literature items containing the results of test in Serbia, Turkey, Norway [9, 16, 17] clearly indicate that facilities such as SHPP, despite their relatively small scale (installed power, extensive area related to the facility's infrastructure, etc.), may have a significant negative impact on environment. It depends on the extent to which the negative impact of SHPP facility on environment and the method for reducing this impact were taken into account, already at the designing stage. It should be borne in



mind that the term "small" in the definition of an SHPP facility refers mainly to the turbine power, and not to the size of the accompanying hydrotechnical facilities (e.g. dam) [18, 19]

There are the following advantages of SHPP:

- improving the runoff coefficient, especially on smaller rivers,
- potential retention and flood protection function resulting from water damming,
- clean and waste-free energy production.

The limitations indicated above (potential negative impact of SHPP infrastructure on the environment) do not apply to the concept described in this article, because the suggested approach does not require constructing the hydrotechnical facilities on the surface. The existing conditions are used, and technical work is related to possible adjustment of the water intake, installation of the hydro-generator unit in a selected location and introduction of necessary changes in the construction of pipelines [20, 21, 22].

This is also the main advantage of the suggested solution - no harmful impact on the environment, while at the same time utilizing the energy of the water stream by transforming it into electricity. Additionally, the experience gained will enable proposing the improved SHPP technology, adapted to the hydrological conditions of the mine, which, on a scale related to the number of available shafts, may provide measurable benefits regarding the amount of energy produced.

A disadvantage may be the relatively low power of the generator in relation to the power of equipment existing in the mine. For example, the estimated power of the generator is approximately 200 kW, with the demand of the main drainage pumps ranging from several to tens MW.

Activities related to the liquidation of mines (including KWK Boże Dary mine), as well as post-liquidation procedures, are energy demanding. An example are pumping stations, which still have to pump water after the mine is closed. This requires electricity, most of which comes from burning fossil fuels. This forced to take a number of actions aimed at reducing the demand for the so-called "grey energy" produced from fossil fuels by introducing pro-ecological solutions.

The project related to the production of electricity in the mine assumed the following three main assumptions:

- use of water energy,
- reducing the demand for electricity,
- implementation of innovative solutions in the mining industry.

The above assumptions were the reason for launching the hydro-generator in the pumping station in Boże Dary mine. This is the first solution of this type in the European mining industry. The hydrogenerator was built at a level of 416 m in a former underground mining plant. It allows the production of clean electricity using the energy of water dropped from a level of 183 m to a level of 416 m.

It must be remembered that water must be constantly pumped out of closed mines and the pumps need energy to operate. Moreover, energy is necessary for operation of fans, control and measuring equipment, operation of the hoisting machine and lighting. Installing the water system ensuring the water flow through the hydro generator (Fig. 1) will enable producing electricity, which will then be consumed in the pumping station. It is estimated that the average annual electricity production in this case will amount to just under 1,600,000 kWh. Such action will significantly reduce the cost of purchasing electricity and its distribution services. Taking into account the current market situation regarding the electricity price, we can count on a quick payback. Payback time is estimated at a maximum of 2.5 years. It should be emphasized once again that all electricity will be consumed at the point of production and is not expected to be directed to the local operator's distribution network.



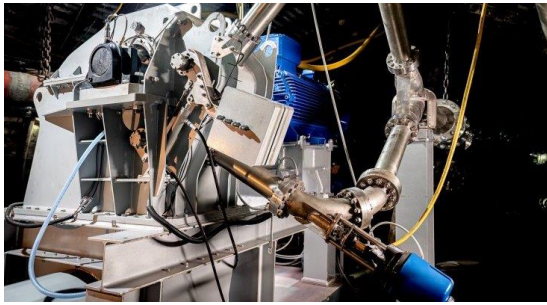

Fig. 1. Hydro-generator installed in the Boże Dary mine [23]

Mining plants have many hydraulic installations that can potentially be used to produce electricity. The conditions for using water energy are the following:

- enough height of water fall,
- local technical capabilities.

Potential places for using the water turbines in mines are the following:

- gravity water discharge from not deep levels,
- water outflow from the main drainage pipelines when pumping from deeper to shallower levels,
- water flow from the main drainage pipelines on the surface,
- cascade flows of mine water in the beds of under surface streams.

Depending on the choice of location, various designs of water turbines can be used [24, 25, 26]. Examples of design diagrams are shown in the below figures (Fig. 2 to Fig. 5).

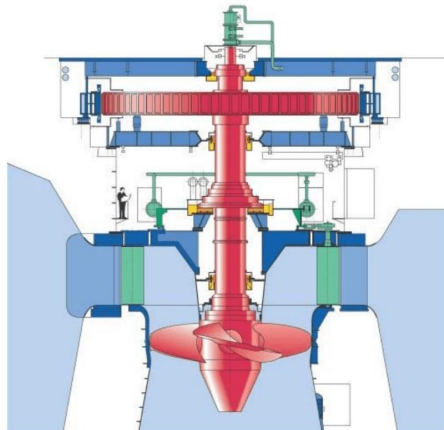

Fig. 2. Schematic diagram of Kaplan turbine [27]

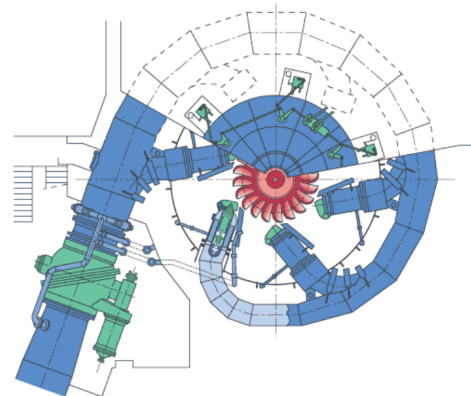

Fig. 3. Schematic diagram Pelton turbine [28]

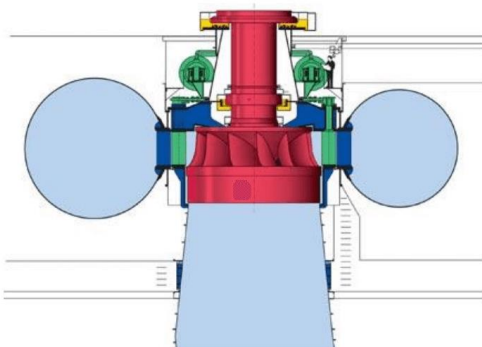

Fig. 4. Schematic diagram of Francis turbine [29]

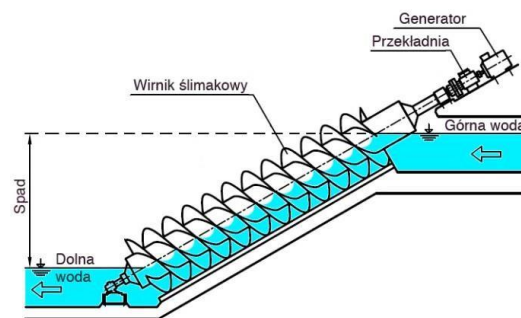

Fig. 5. Schematic diagram of Archimedes turbine [30]

Installation of a hydro-generator in the Boże Dary mine pumping station (Fig. 1) is the first pilot project of such type. Electricity savings were observed after just a few days of operation of this unit. This clearly indicates that further investments of this type are absolutely justified. Taking into account stable operating conditions, due diligence of the properly trained staff and regular inspections and services, the device will operate without failure for at least a dozen or so years [31, 32, 33, 34, 35, 36, 37].

Currently, similar projects are planned to be implemented in the branches of KWK Centrum mine and KWK Pokój I - Pokój II mines. Additionally, it is possible to install lower-power hydro-generators at pumping stations on discharge collectors (the average power of one collector is from 30 to 40 kW).

The CZOK branch currently has 16 pumping stations, and soon there will be 18 of them. Therefore, there is great potential to implement further innovative projects of this type, which will bring significant savings.

4. KOMAG solution

At KOMAG, in cooperation with specialists from the Silesian University of Technology, conceptual work has been started several years ago on one of the solutions for a power plant with a vertical axis of rotation. Fig. 6 (half-cross-section) shows a water power plant according to the idea of the author's team.

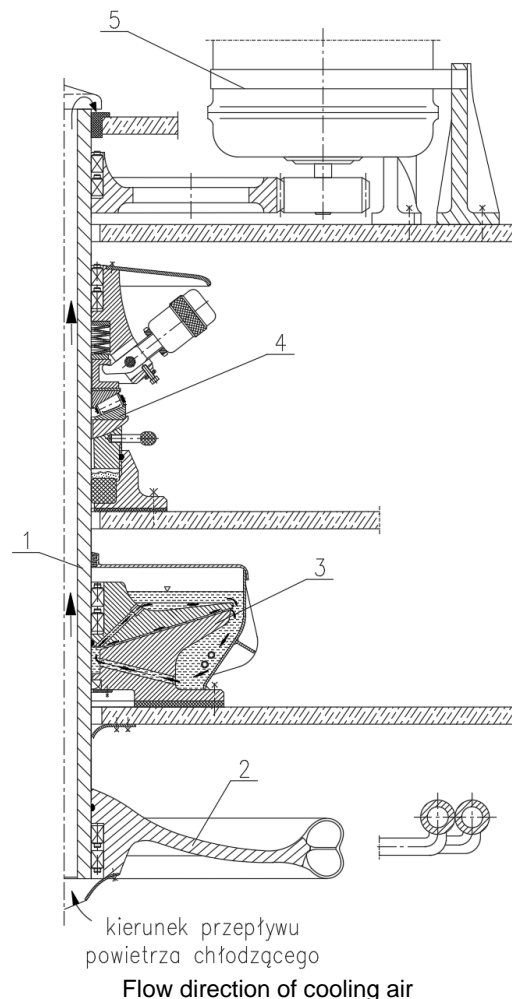

Fig. 6. Water power plant according to the idea of the author's team [38]:

1 - tubular shaft, 2 - Pelton turbine rotor, 3 - main longitudinal-transverse plain bearing with hydrodynamic lubrication, 4 - rolling bearing supporting the start with an automatic load switching system, 5 - electric generator with auxiliary devices

Bearing of machine shafts with a vertical axis of rotation in machine construction often poses a number of specific design and operational problems. They result from the fact that the loads, especially longitudinal ones, on such shafts during the start-up phase are generally significant, and their rotational speed is most often variable in a wide range. There are often a number of additional requirements, such as the need to reduce noise or reduce resistance during rotation [39].

Shafts of hydroelectric power plants, especially of the dam type, most often operating continuously, are equipped with Kingsbury-Michel type segmental plain bearings with swingingly supported segments as ring sections. Such bearings operate quite well under hydrodynamic lubrication at nominal rotational speed, but are sensitive to large changes in sliding speed during bearing start-up and run. These structures are highly complex, expensive and require special cooling of lubricating oil systems, what significantly reduces the overall energy efficiency of the power plant. During the start-up phase, which must take place under full longitudinal load, such bearings are usually additionally lubricated hydrostatically, what additionally requires using the special, high-pressure lubricating oil pumps and proper automatic system for switching the operation of the lubrication and oil cooling system. The same difficulties occur during bearing overrun when the motor is stopped. Such solutions are unsuitable in a situation where the start-up, and therefore the run of the power plant must take place with increased frequency, as is the case of peaking power plant according to the concept presented in the article.

In the solution for the vertical shaft bearing of the discussed water power plant powered by the drainage system of a deep mine, it was suggested to use a special hybrid bearing, which in the range of nominal rotation speed transfers the longitudinal and transverse load through a plain bearing with liquid lubrication, and during the start-up and overrun, this bearing is supported by additional rolling bearing, automatically disconnected after the motor shaft reaches the set rotation speed, what allows for the hydrodynamic lubrication in the plain bearing.

When sliding of the journal on the bearing shell is sufficient, the load is switched between both types of bearings automatically at the set rotation speed.

As part of the conceptual work, two variants of the plain bearing were suggested. The first one is a longitudinal-transverse bearing lubricated with oil in a closed circuit. In the second variant, it is suggested to use high-pressure water in the mine's main drainage pipeline, which, after proper separation of impurities, lubricates the plain bearing, thus creating a system with basic hydrostatic lubrication, additionally supported by the hydrodynamic lubrication. Water as a lubricating and cooling medium in this variant works in an open system, i.e. after passing through the sliding bearing, it is discharged into the lower mine water tank, transporting the heat generated in the bearing. In both variants, the longitudinal bearing load Q consists of the sum of the weights of all components installed on the shaft and the weight of the shaft itself.

Lubrication grooves are made on the sliding surface of the journal. These grooves make lubricating wedges with high load-bearing capacity, forming when the journal slides on the bearing. In this way, nature of operation of the suggested plain bearing is similar to that of the Kingsbury-Michell type bearing, ensuring its very high load-bearing capacity.

The lubrication grooves additionally act as blades of a centrifugal pump, causing intensive circulation of the lubricant, shown as arrows in Fig. 7, to effectively remove the heat generated in the bearing slip zone, regardless of whether it is lubricated with oil or water.

In the variant of the bearing with oil lubrication, the lubricant returns to the bearing entrance after cooling, what is additionally facilitated by the gravitational forces caused by the change in oil density as a result of the temperature difference. If necessary, the oil cooling system can be equipped with an internal coil through which part of the water supplying the power plant or water from the mine's fire protection system flows for sufficient oil cooling.



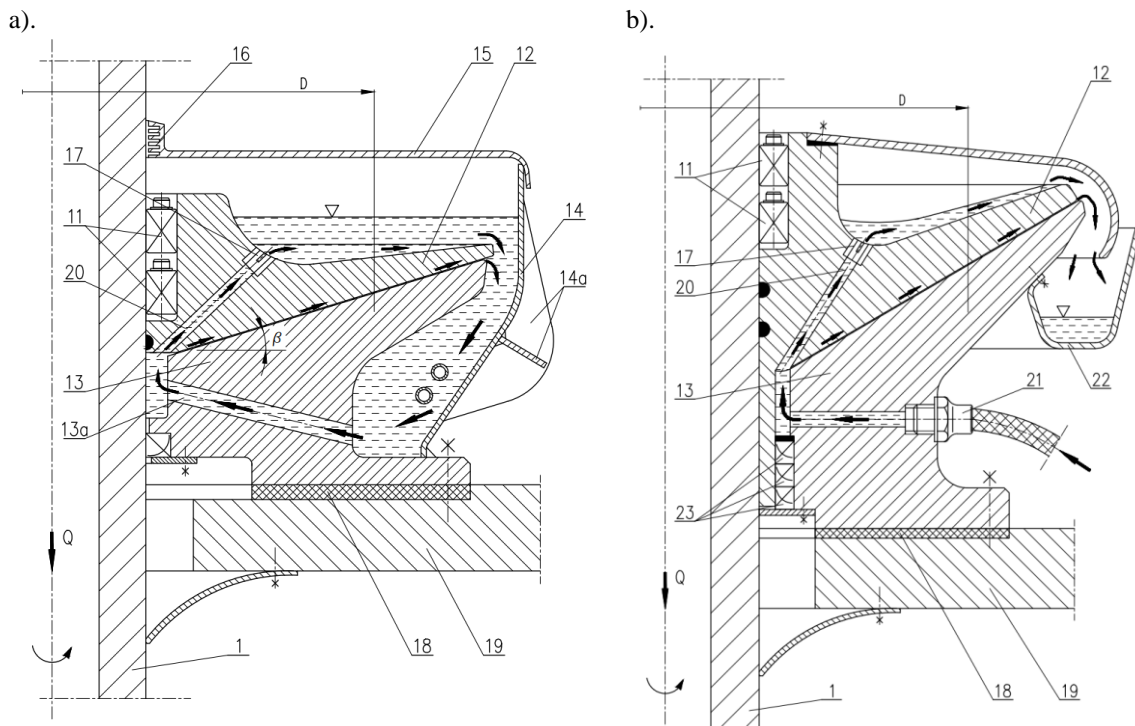

Fig. 7. Main longitudinal-transverse plain bearing with hydrodynamic lubrication in two lubrication variants [38]: a) oil lubrication, b) high pressure water lubrication

Optionally, additional inclined holes can be made in the journal, ending with adjustable nozzles through which part of the lubricating liquid flows onto the upper surface of the journal, enhancing its cooling.

In addition to transferring the main longitudinal load Q , both variants of the plain bearing also transfer transverse forces that may occur during operation of the power plant bearing system. In the case of a tapered journal, the amount of lateral force that the plain bearing can transfer depends on the "beta" cone angle. The large average diameter D of the bearing sliding surface allows for high load-bearing capacity because the average contact pressures decrease and the average sliding speed in the bearing increases. This enables obtaining the hydrodynamic lubrication at a significantly reduced rotation speed of the motor shaft, which is very desirable in the suggested solution. The polymer underlay (18) dampens vibrations and noise.

High water pressure in the drainage pipeline from which the power plant is supplied leads to the suggestion of using the water as a lubricant. The unfavourable property of water in relation to oil in the form of low water viscosity can be compensated by its high pressure, what allows obtaining an additional hydrostatic lubrication in addition to the hydrodynamic lubrication described earlier.

Fig. 7 b) illustrates a variant of a plain bearing in which water for lubrication and cooling of the bearing is supplied through connection (21) attached to the bushing (13). Water from the drainage pipeline should be pre-cleaned to remove mechanical impurities, while typical chemical impurities in mine water are not important with appropriate anti-corrosion protection of the components. After flowing through the bearing, the water flows into the surrounding gutter (22), from where it is directed to the lower tank together with the water that flows through the turbine rotor. The high-water pressure zone in the bearing is sealed against the moving part of the journal with a multi-stage lip seal.

Regardless of the plain bearing variant in the presented water power plant concept, it operates only when there is liquid lubrication system. During start-up and during run, when the sliding speed does not allow obtaining the effect of liquid lubrication, it is suggested to use a special system that relieves

the plain bearing and protects against operation in semi-dry friction conditions, which may lead to rapid increase in abrasive wear of the journal and bushings, with the risk of seizure symptoms. High resistance to movement when liquid lubrication is not guaranteed is also very unfavourable. The system that relieves the load on the plain bearing during start-up and run uses a supporting rolling bearing that is switched on automatically. This system is illustrated in Fig. 8.

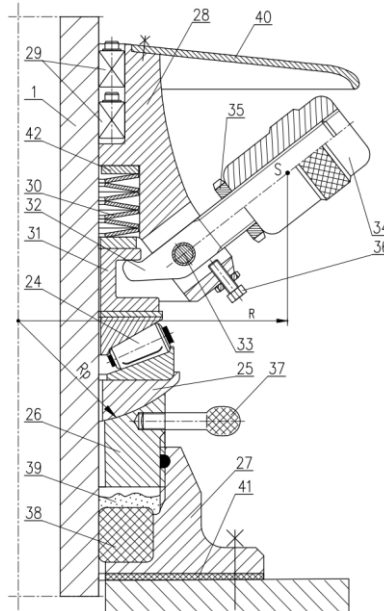

Fig. 8. System that relieves the plain bearing [38]

The system works as follows. During standstill and start-up, full load on the shaft (item 1 in Fig. 6) is transferred by the supporting rolling bearing (24), which reduces starting resistance. It is preferable to use a tapered roller bearing, capable of transferring the significant longitudinal and transverse loads. The bearing (24) supporting the start-up is based on a spherical support (25) alleviates uneven stress distribution resulting, for example, from manufacture deviations of the components.

When the shaft rotation speed increases after starting the power plant, the inertial-lever mechanism begins to operate (upper part Fig. 6). Articulating levers (32) mounted on pins (33) increase pressure on the sliding sleeve (31), which additionally bends the disc spring 30. This gradually relieves the load to the supporting rolling bearing (24), while simultaneously switching the load to the plain bearing, where the conditions for hydrodynamic lubrication are gradually created. The magnitude of the force bending the disc spring at a given rotation speed of the system depends on the mass of the inertial weights (34) and the radius R of the position of their centre of mass S . Position of the weights is adjusted by turning the weights on the fine thread of the articulating levers. After final settlement, position of the weights is locked with locknuts. It is planned to use three levers, evenly distributed around the circumference. At the assumed nominal shaft rotation speed, the load is fully switched to the main plain bearing, and the rolling bearing supporting the start-up stops, waiting for starting the run.

During run, when the rotation speed decreases, the load switching system operates in a reverse direction, gradually transferring the load to the rolling bearing, which transfers the load, until the shaft stops. In this position, the supporting bearing remains ready for restarting. In the extreme position, the articulating levers rest on adjustment screws with locknuts. This eliminates the possibility of vibrations in the system, which may arise, for example, due to manufacture deviations in the components.

5. Control of the components of the peak power plant supplied with mine water

The design and principle of operation of the discussed power plant is such that, apart from the electrical systems, the control of which will be omitted in this research work, the power plant does not require any special control, apart from the bearing system of the vertical shaft of the power plant.

After assembling the power plant, careful adjustment is required to determine the most favourable shaft rotation speed at which the load, described in the previous chapter, is switched from the rolling bearing supporting the start-up and run to the main bearing of the power plant, which is a plain longitudinal-transverse bearing with hydrodynamic lubrication. The lack of significant hysteresis in the switching system means that the rotation speed at which switching should be for both switching directions is practically the same. This rotation speed should be determined through operational tests at the lowest possible level so that the load switching takes place smoothly, without any significant disturbances or acceleration in the shaft rotation. This determination should be made by rotating all inertial weights in the same way at a standstill, thus changing the rotation radius R equally for all the weights. A favourable condition for the operation of a plain bearing, regardless of whether it is an oil- or water-lubricated variant, is a possibly constant temperature at the installation site of the power plant, what means that there is no significant impact of the ambient temperature on the change in the viscosity of the lubricant. However, it should be periodically checked for changes that may cause the above-mentioned undesirable phenomena during switching, e.g. caused by wear of system components.

Mechanism for positioning the supporting rolling bearing requires particularly careful, one-time adjustment (Fig. 8, item 24). This adjustment should be made before determining the optimal rotation speed at which the load is switched, as described above. The above-mentioned bearing supporting the start-up is loosely mounted on the shaft (1) and rests on a spherical support (25), ensuring even distribution of the load to the rolling components. The spherical support rests on the adjustment sleeve (26), which is connected to the base (27), attached to the ceiling of the chamber in which the power plant is installed.

Rotating the adjustment sleeve serves to precisely position the supporting rolling bearing relative to the load switching mechanism previously described. This adjustment is best performed according to the following procedure (before filling the sliding bearing with oil or with the water supply as a lubricant closed): By turning the adjusting sleeve (26) while standing still, the main sliding bearing should be fully loosened, which will result in great ease of turning the shaft, because then the full the longitudinal load Q will rest only on a rolling bearing with low resistance to movement. Then gradually lower the adjustment sleeve until the journal of the plain bearing comes into contact with the bush. The signal that this condition has been reached will be a sharp increase in the resistance to rotation of the shaft, especially when there is no lubricant in the bearing. Then the adjusting sleeve should be raised again by the determined amount resulting from the structure of the slide bearing relief system. Such a position will be characterized by a large decrease in the resistance to rotation of the shaft, and the disc spring (30) will obtain an initial deflection. In this position, fill the sliding bearing with oil to the appropriate level or open the water supply to act as a lubricant in the case of water lubrication of the bearing.

Correctly performed bearing adjustment is a condition for maintaining a very high operational durability.

6. Conclusions

Cost of electricity is the result of many factors, including production costs, distribution costs, energy policy as well as supply and demand. The introduction of renewable energy sources and technologies that increase energy efficiency can help to stabilize or reduce energy costs in the future.

Water power plant in an underground mine is an innovative solution that uses underground and industrial water present in closed or active mines to produce electricity. Water flowing from a higher



to a lower level drives a turbine that generates electricity. The key advantages of this solution are as follows:

- use of existing infrastructure - adaptation of existing systems of workings / tunnels and pumps in mines reduces investment costs,
- sustainable development – the use of a renewable energy source, such as water, supports environmental protection and reduces greenhouse gas emissions,
- water management – water power plants in mines help in managing mine water, if it is only pumped, it can reduce the problem of water drainage and purification,
- effective water management – it can help in the controlled drainage of water to the mine surface, which is beneficial from the point of view of ecology and water management,
- energy stability – provides a stable and reliable source of energy that can support local communities and industry,
- examples of application - in the world, but also in Poland, there are functioning water power plants in underground mines, which prove their effectiveness and profitability.

Water power plants in underground mines offer a sustainable energy solution that not only uses the resources of mines after their operation, but also contribute to development of green energy production and environmental protection. The author's solution with a vertical pipe shaft presented in the article fits very well into the problem of water power plants used in underground mines. It is characterized by particularly high durability of the system bearings. It results from the fact that the main plain bearing operates only under full hydromechanical lubrication, i.e. practically without wear, while the rolling bearing that supports starting and run during braking operates for short time intervals and at reduced rotational speed. For the same reasons, the bearings of the vertical shaft of the power plant emit low noise with low vibration. Low resistance to movement under the nominal rotation speed of the power plant ensures high energy efficiency of the bearing as well as the operational durability of the entire power plant according to the described concept.

References

- [1] Small water power plants: https://www.tew.pl/biblioteka/opracowania/1992_Hoffmann_MEW_Poradnik.pdf (22-12-2023)
- [2] Lazar D., Szweda S.: Koncepcja układu odzyskiwania energii z rurociągu szybowego Masz. Gór. - 2017, 3, 64-74.
- [3] Dorosiński M.: Pionierskie rozwiązanie w bożych darach. Wykorzystanie wód kopalnianych do produkcji energii. (A pioneering solution in Boże Dary mine. Use of mine water for energy production) Trybuna Górnicza 15 September 2023, No. 37 (1506), p. 7
- [4] Bill of 9 June 2011. Geological and mining law. Polish Journal of Laws. No 163 item. 981 with further amendments.
- [5] Regulation of the Minister of Energy of November 23, 2016 on detailed requirements for the operation of underground mining plants. Polish Journal of Laws. 2017 item. 1118 with further amendments.
- [6] Bill of 20 July 2017 r. Prawo wodne (Water law). Polish Journal of Laws.. 2017 item 1566 with further amendments Tian, J., Hu, X., Dai, L., Yang, L., Yang, Y., Mallick, R., 2021. Kinematics and dynamics analysis of new rotary-percussive PDM drilling tool. Journal of Low Frequency Noise, Vibration and Active Control 40, 1695–1711. <https://doi.org/10.1177/1461348421989156>
- [7] PGW Wody Polskie: <https://www.wody.gov.pl/nasze-dzialania/potwierdzenie-zgodnosc-z-celami-srodowiskowymi/114-nieprzypisany/487-faq> (22-12-2023)
- [8] Flizikowaki J.: Przykład innowacji konstrukcji małych elektrowni wodnych (Example of small power plants innovative designs), Projekt, Nasza energia w województwie kujawsko-pomorskim, Program operacyjny województwa kujawsko-pomorskiego 2007-2013
- [9] Small water power plants in Poland: https://ungc.org.pl/wp-content/uploads/2022/03/Raport_Male_elektrownie_wodne_w_Polsce.pdf (22-12-2023)



- [10] Energy, Climate change, Environment:
https://ec.europa.eu/energy/sites/ener/files/documents/6.2_niemann_energy_storage.pdf (22-12-2023)
- [11] Germany converting a huge coal mine into giant renewable battery:
<https://www.independent.co.uk/news/world/europe/germany-coal-mine-convert-renewable-battery-hydroelectric-prosper-haniel-northrhine-westphalia-a7648841.html> (22-12-2023)
- [12] Germany Converts Coal Mine Into Giant Battery Storage for Surplus Solar and Wind Power:
<https://www.ecowatch.com/coal-mine-hydroelectric-2321724350.html> (22-12-2023)
- [13] Germany is Converting a Coal Mine Into a Massive Renewable Energy Battery:
<https://www.sciencealert.com/germany-is-converting-a-coal-mine-into-a-massive-renewable-energy-battery> (22-12-2023)
- [14] Pistelok P., Rossa R.: Małe elektrownie wodne jako źródło energii odnawialnej (Small water power plant as a source of renewable Energy), Rynek Energii ,2014, Nr 2(111), s. 75
- [15] Germany. The second life of the last hard coal mine: <https://www.dw.com/pl/to-by%C5%82a-ostatnia-kopalnia-w%C4%99gla-kamiennego-w-niemczech-teraz-zyskuje-swoje-drugie-%C5%BCycie/a-59598714> (22-12-2023)
- [16] Środowiskowe wyzwania małych elektrowni wodnych (MEW):
<https://swiatwody.blog/2022/03/18/srodowiskowe-wyzwania-malych-elektrowni-wodnych-mew/> (22-12-2023)
- [17] Difficult situation of small hydropower plants: <https://www.teraz-srodowisko.pl/aktualnosci/Trudna-sytuacja-malych-elektrowni-wodnych-540.html> (22-12-2023)
- [18] Praca zbiorowa: Jak zbudować małą elektrownię wodną. Przewodnik inwestora, European Small Hydropower Association (ESHA), Instytut Maszyn Przepływowych PAN, Bruksela/Gdańsk, 2010
- [19] Praca zbiorowa: Mikroelektrownie i małe elektrownie wodne. Kompletny podręcznik odbudowy, European Small Hydropower Association (ESHA), 2014.
- [20] Goryca Z., Peczkis G.: Hydrogenerator do mikroelektrowni wodnej. (Hydrogenerator for water micro-power plant). Napęd i sterowanie, grudzień 2020, nr 12, s. 52
- [21] Prusek A., Tytko R.: Prądnice synchroniczne (hydrogeneratory), regulatory, budowa, zasada działania, Aura, 2017, Nr 10 s.14
- [22] Rossa R., Pistelok P.: Generator z magnesami trwałymi do pracy w agregacie prądotwórczym (Generator with permanent magnets for operation in power generator). Prace Naukowe Instytutu Maszyn, Napędów i Pomiarów Elektrycznych Politechniki Wrocławskiej nr 66, Studia i Materiały nr 32/2012.
- [23] Hydrogenerator installed in Boże Dary mine underground
<https://inzynieria.com/energetyka/wiadomosci/67357,w-katowicach-wody-kopalniane-sluza-do-produkcji-energii-elektrycznej> (05-06-2024)
- [24] Biały W: Podstawy maszynoznawstwa (Basics of machine science. Scientific Publishing House PWN, Warszawa 2017.
- [25] Sobczyk A., Walczak P.: Hydrauliczny system sterowania turbiny wodnej (Hydraulic control system for a water turbine), 20th Polish Conference CYLINDER 2010 "Testing, design, manufacture and operation of hydraulic systems, Rytro, 2010, Poland.
- [26] Walczak P.: Badania hydraulicznego układu sterowania kierownicą turbiny wodnej małej mocy (Testing the hydraulic system to control small power water turbine), Politechnika Krakowska Wydział Mechaniczny Instytut Konstrukcji Maszyn Zakład Napędów Hydraulicznych i Transportu Bliskiego, Doctoral thesis, Kraków 2016.
- [27] Diagram of Kaplan turbine
https://pl.wikipedia.org/wiki/Turbina_Kaplana#/media/Plik:S_vs_kaplan_schnitt_1_zoom.jpg (19-06-2024)
- [28] Diagram of Pelton turbine
https://pl.wikipedia.org/wiki/Turbina_Peltona#/media/Plik:S_vs_pelton_schnitt_1_zoom.png (19-06-2024)
- [29] Diagram of Francis turbine
https://pl.wikipedia.org/wiki/Turbina_Francisa#/media/Plik:M_vs_francis_schnitt_1_zoom.jpg (19-06-2024)



- [30] Diagram of Archimedes turbine <https://instsani.pl/technik-urzadzen-i-systemow-energetyki-odnawialnej/vademecum-energetyki-odnawialnej/energia-wod-plynacych/budowa-i-zasada-dzialania-turbin-wodnych/turbina-slimakowa/> (19-06-2024) <https://srk.com.pl/media/aktualnosci/idn:432> (05-06-2024)
- [31] Hydrogenator is already producing and ...saves <https://srk.com.pl/media/aktualnosci/idn:432> (05-06-2024)
- [32] Mine water can be turned into clean energy. The Mine Restructuring Company showed how to do it <https://nettg.pl/gornictwo/200743/kopalniane-wody-mozna-zamienic-w-czysta-energie-spolka-restrukturyzacji-kopaln-pokazala-jak-to-zrobic> (05-06-2024)
- [33] Minkiewicz H., Pastwa D.: Metody zabezpieczania turbin wodnych od rozbiegu, Napędy i sterowanie, grudzień 2019, nr 11, s. 72
- [34] A pioneering solution in Boże Dary mine. Use of mine water for energy production <https://srk.com.pl/media/aktualnosci/PIONIERSKIE-ROZWIAZANIE-W-BOZYCH-DARACH.-WYKORZYSTANIE-WOD-KOPALNIANYCH-DO-PRODUKCJI-ENERGII.-/idn:415> (05-06-2024)
- [35] A pioneering solution in the Boże Dary pumping station - use of mine water for energy production <https://nowa-energia.com.pl/2023/09/15/pionierskie-rozwiazanie-w-pompowni-boze-dary-wykorzystanie-wod-kopalnianych-do-produkcji-energii/> (05-06-2024)
- [36] Publication of IOZE hydro użytkownika https://pl.linkedin.com/posts/ioze-hydro_pelton turbine-hydropower-turbinapeltona-activity-7125070751233138688-EJGC (05-06-2024)
- [37] Use of mine water for energy production. SRK will check it <https://nettg.pl/gornictwo/199405/wykorzystanie-wod-kopalnianych-do-produkcji-energii-srk-to-sprawdzi/set/page/1> (05-06-2024)
- [38] Mikuła St. et. al: A peak water power plant powered by a deep mine drainage pipeline. patent application number in the Polish Patent Office P.444397. 2023.
- [39] Szelka M. i inni: Węzeł łożyskowania siłowni wiatrowej o pionowej osi obrotu, nr zgłoszenia patentowego w UPRP P.440590. 2022

